

Expansion joints can be made using pre formed 8 or 10mm closed cell Polyethylene foam with a self-adhesive t-bar base known as a vertical control joint. Joints may be needed due to large areas, door thresholds or in between under floor heating circuits, this detail is particularly well suited to under floor heating as it eliminates cutting the screed.

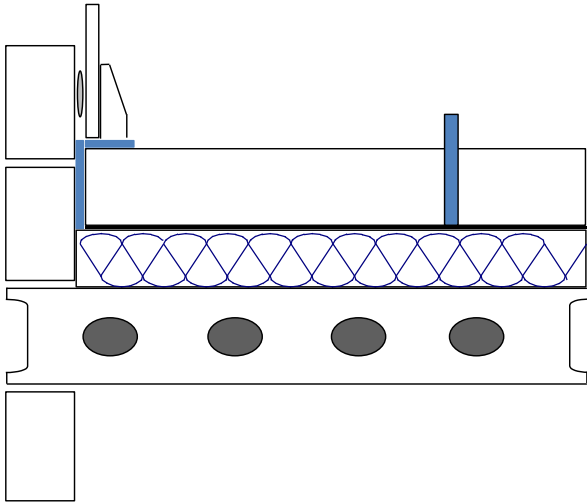

- Insulation, DPM and Edge detail installed as Normal.
- Joint strip attached to DPM where expansion joints are required using self-adhesive base, they should also be secured using additional screed tape to improve bond.
- Where the strip meets either walls or door frames these joints should be sealed using tape.
- Install Screed as per Gyvlon Installation Guide and Gyvlon NBS M13 Specification
- Once the screed has cured the joint Strip can be trimmed to screed level using a suitable knife.

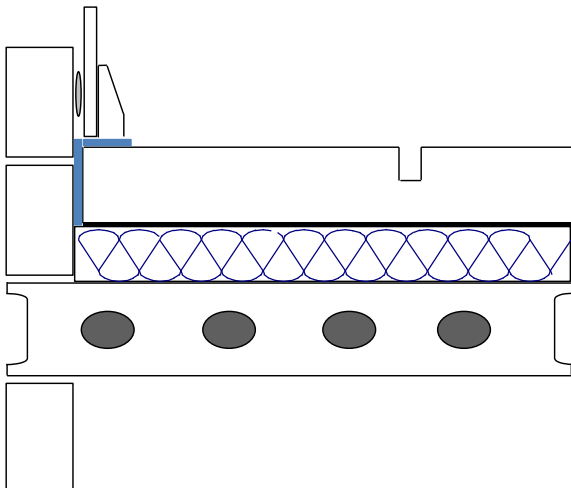

Contraction joints can be cut into the screed following its installation.

- Insulation, DPM and Edge detail installed as Normal.
- Install Screed as per Gyvlon Installation Guide and Gyvlon NBS M13 Specification
- Saw cuts should be formed as early as possible following the screed being installed (2-3 Days)
- Saw cuts should be made to half the screeds depth using a floor saw with suitable blade.
- Saw Cuts should be a minimum of 5mm wide
- Joints can be filled using a flexible sealant.

Note: Saw cut joints should be avoided when using under floor heating, for under floor heating joint please see preformed joints.

Note: For maximum bay sizes and dimensions please see Gyvlon Installation guide, or contact our team of Technical Specification Managers